

DIGIMIX

MECHANICAL AGITATOR FOR ANAEROBIC DIGESTION TANK

DIGIMIX – VERTICAL AGITATOR WITH AXIAL FLOW

To homogenize sludge and
to keep it in suspension
for tanks up to 15 000 m³

- Inside the process of sludge treatment
- Strongly built and reliable
- Guarantees optimum efficiency
- Easy installation and maintenance

TREATMENT OF SLUDGE
FROM INDUSTRIES
AND MUNICIPALITIES



DIGIMIX

MECHANICAL AGITATOR FOR ANAEROBIC DIGESTION TANK

- **Specific operating conditions**
Atex explosive zone, biogas gaseous roof, operating 24h/24, 40 g/l concentrated sludge, 30 to 60 mbars pressure, 38°C temperature.
- **Strongly built and reliable components**
Atex motorization up to 37 kW
Raising support with conical rollers bearings to guide very long agitation shafts (up to 25 meters).
- **Efficient propellers**
The geometry of Mixel TTF propellers increases the energetic efficiency of DIGIMIX.
- **An easy to use agitator**
Easy to assemble on the tank thanks to the specially designed fixing flange and to the propellers blades fixing system.
Easy to maintain thanks to hydraulic sealing system, without wearing part.

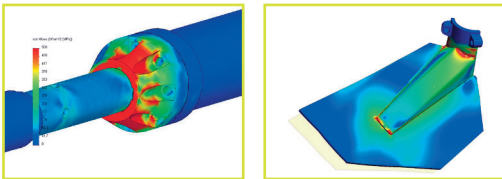

Calculation of mechanical strength



Installation for methanization of waste water plant sludge



Digestion tank (with several agitators) - Baraki - Algeria

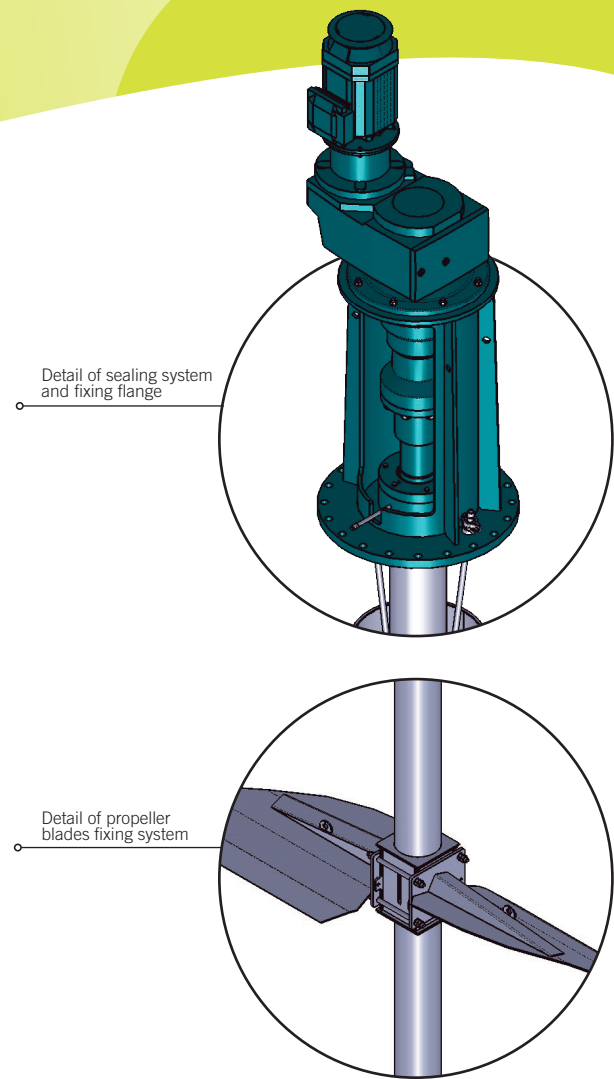

Our references :
OTV (Annaba Algeria, Khourigba Morocco, Sour Tyr Lebanon...)
BIWATER (Tamuda bay Morocco...)
VA TECH WABAG (Baraki Algeria...)
KDM (Korea)
Biogaz Du Pays de Château Gontier (France)

Mixel pictures – pictures and document are not contractual

mixel
agitators